

# FEIDER

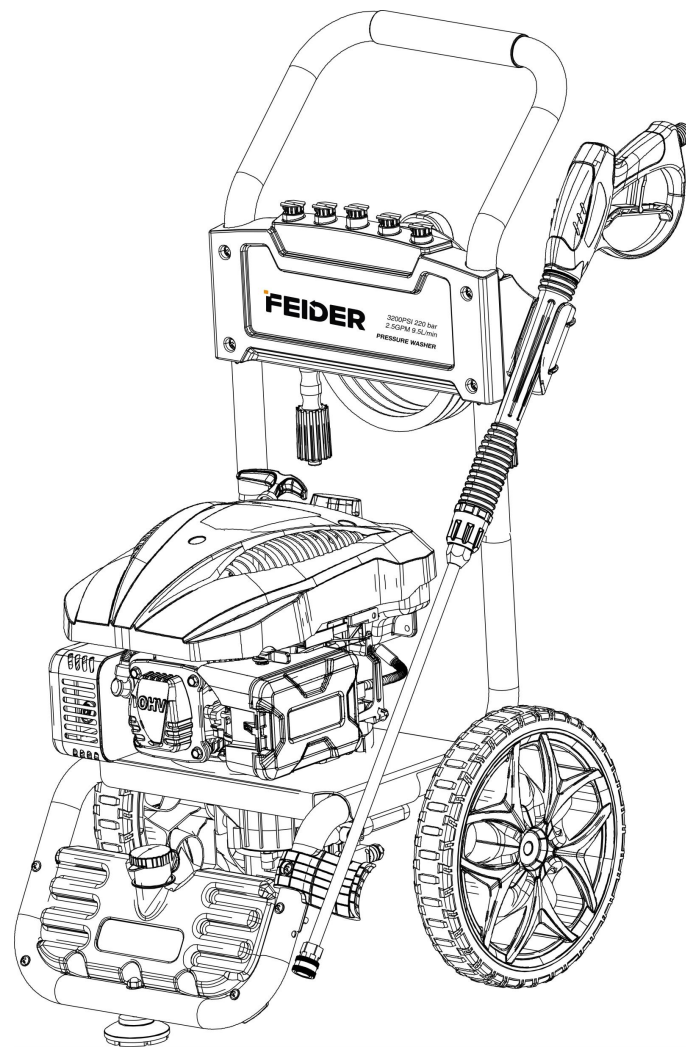

**PETROL HIGH PRESSURE WASHER**  
**FNHPT240**  
**USER GUIDE**

**CAUTION : Read the instructions before using the machine !**

# CONTENTS

|                                   |    |
|-----------------------------------|----|
| 1. SAFETY INSTRUCTIONS.....       | 3  |
| 2. YOUR PRODUCT.....              | 9  |
| 3. ASSEMBLY.....                  | 10 |
| 4. OPERATION.....                 | 13 |
| 5. MAINTENANCE AND STORAGE.....   | 16 |
| 6. TROUBLESHOOTING.....           | 18 |
| 7. WIRING DIAGRAM.....            | 19 |
| 8. DECLARATION OF CONFORMITY..... | 20 |
| 9. WARRANTY.....                  | 21 |
| 10. PRODUCT FAILURE.....          | 22 |
| 11. WARRANTY EXCLUSIONS.....      | 23 |

## 1. SAFETY INSTRUCTIONS

- Read all instructions before using the machine.
- Use this unit as described in this manual. Any mishandling and any use contrary to instructions for use shall in no case be the responsibility of the manufacturer.
- Follow all instructions given in this manual regarding putting into service, safe operation, handling, transportation and storage of the machine. Always take into account the weight of the machine.
- Failure to observe the safety and operating instructions may result in a risk of fire and / or personal injury.
- If you are giving this unit to another person, please also provide this manual.
- Do not use attachments other than those recommended by the manufacturer; they can damage the unit and / or cause injury.
- This machine should not be used by children. Children should be supervised to ensure that they do not play with the appliance.
- This machine is not intended for use by persons (including children) with reduced physical, sensory or mental capabilities, or lack of experience and knowledge.
- Do not disassemble the device yourself. Any disassembly, repair or inspection should be carried out exclusively by a qualified person.
- **WARNING:** This machine is intended for use with a cleaning agent supplied or recommended by the manufacturer. Use of other cleaning or chemical agents may affect the safety of the machine.
- **WARNING:** High pressure jets can be dangerous if

misused. The jets should not be directed to people, electrical equipment or the machine itself.

- WARNING: Do not use the machine near people unless they wear protective clothing.
- Do not direct the jet against yourself or others to clean clothes or footwear.
- WARNING: Risk of explosion. Do not spray flammable liquids.
- WARNING: High pressure cleaners should not be used by children or untrained persons.
- WARNING: Pipes, fittings and connectors are important for the safety of the machine. Only use hoses, fittings and connectors recommended by the manufacturer.
- WARNING: To ensure the safety of the machine, use only the original manufacturer's parts or approved by the manufacturer.
- WARNING: Water that has flowed through the flow shutters is considered to be unsafe.
- WARNING: The machine must be switched off by putting the ON/OFF switch on the OFF position during cleaning or maintenance and when replacing parts or converting the machine to other functions.
- WARNING: Do not operate the machine if any important parts are damaged, such as safety devices, high pressure hoses or the trigger gun.
- WARNING: Do not use combustion engine powered machines indoors unless adequate ventilation is assessed by national labor authorities.
- WARNING: Make sure there are no exhaust emissions near the air intakes.
- WARNING: It is important to provide adequate

ventilation and make sure that the flue gases are properly discharged.

- **WARNING** Incorrect fuels shall not be used as they may prove hazardous.
- Children, animals and persons not participating in the use of the machine must remain at a minimum distance of 10 meters from the sprayer.
- The high pressure hose must remain connected to the compressor as long as the system is under pressure.
- Do not use corrosive or flammable liquids in the machine.
- The appliance must be connected to a water supply using a new set of hoses; the old pipe set must not be reused.
- When using the machine, wear protective equipment including safety goggles, safety shoes, safety gloves, safety helmet with visor and double-insulated hearing protection.
- In order to move the unit easily, bend the lance.
- **Warning:** When you activate the machine, the great pressure of the water coming out of the pipe can create a kickback; Pay attention to the movement of the lance. Hold it tight. The force of the kickback is greater than 20N.
- Before assembling, dismantling, repairing, transporting, servicing and storing, check if the machine switched-off.
- Handle the unit with care, do not drop it.
- Do not use the machine in extreme weather conditions, when it is very cold. Do not use the machine with ice water.
- Use the tool in a stable and plane location.

- When transporting the machine, take note of its weight. Do not overestimate your efforts and get help if necessary.
- The machine must be transported from one point to another and switched off and. Always use the transport handle.
- Improper transport of the machine may result accidents and injuries.
- During use, transport, assembly, disassembly, in case of failure, during foreseeable tests or breakdowns, the tool must always remain upright.
- Do not use the tool in dangerous situations or when an accident has occurred. Do not use it indoors, in places where exhausted gases can be emitted, etc.
- When opening the trigger gun, pay attention to the kickback force. The power of the gun can cause a kickback and can produce a loss of control of the gun and create accidents and injuries. Hold the gun firmly, and with both hands if possible.
- To avoid dangerous situations in the event of an accident (e.g. contact with or spill of detergents, fuel or oil) or equipment failure (such as a puncture or component failure); please stop to use the machine immediately. Check the problem. Have the machine inspected by a qualified technician. In the event of a spill, move the machine away and clean up spills.
- While using the machine, avoid being under the influence of alcohol and drugs.
- Never spray electrical cables or sockets.
- It is strictly forbidden to add fuel when using the machine.

- Do not touch hot surfaces or place the pipe in contact with hot surfaces of the engine.
- Do not use the machine in a confined space, in order to prevent poisoning by carbon monoxide
- Do not use the unit near fire
- Never operate the machine towards the gasoline.
- Beware of the risk of fire! Do not add fuel while the engine is running. Do not exceed the amount of fuel expected for operation.
- Do not operate the machine if fuel has been spilled; change location, and wait until the device is dry before restarting it.
- Use the machine in an open space and avoid contact with heat generating appliances, such as boilers, water heaters, etc.
- For more safety, use only original spare parts or equivalent parts approved by the manufacturer.
- Do not cover the machine while the engine is running.
- Do not use mobile phones or smoke when filling the fuel.
- Store the cleaner in a dry, airy place, with the empty tank.
- To avoid dangerous situations in the event of an accident (for example, contact with or spill of detergents) or equipment failure (such as a puncture or a component failure), stop using the machine immediately. Check the problem. Have the machine inspected by a qualified technician. In the event of an overflow, move the machine away and clean the overflow.
- **WARNING:** Always turn off the main switch when leaving the machine unattended.

## **Intended use**

Your PRESSURE CLEANER can perform a myriad of tasks in the house and in the garden. It effectively cleans a wide variety of surfaces.

Your PRESSURE CLEANER is designed to operate from a cold water supply.

Your PRESSURE CLEANER has been designed for outdoor use only on materials such as stone, wood and plastics. Please check, before use, whether materials can be cleaned with your sprayer; the manufacturer cannot be held responsible for any damage resulting from improper use.

The main applications of this product are household cleaning tasks such as:







- Cars, motorcycles, bicycles;
- Patios, fences, garden walls, pathways, garages and facades of houses;
- To remove algae and mosses from roofs, brick walls and gutters;
- For cleaning of gardening tools and machinery, furniture and grills;
- For hygiene and maintenance of kennels, stables, etc. and their surroundings;

It is especially useful for cleaning muddy sidings.

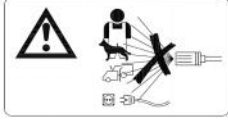
The sprayer alone is capable of performing most of the garden cleaning tasks or on buildings. The detergent is useful for cleaning vehicles and other painted surfaces.



## Symbols

|   |   |
|---|---|
|  | The high-pressure jet must not be directed at persons, animals, live electrical equipment or at the appliance itself. |
|  | The appliance must not be directly connected to the public drinking water network.                                    |
|  | Read instruction manual.  |
|  | Warning symbol.   |
|  | Warning – hot surfaces.   |
|  | Do not touch hot surfaces.  |
|  | Guaranteed sound power level.   |

## 2. YOUR PRODUCT

### Description

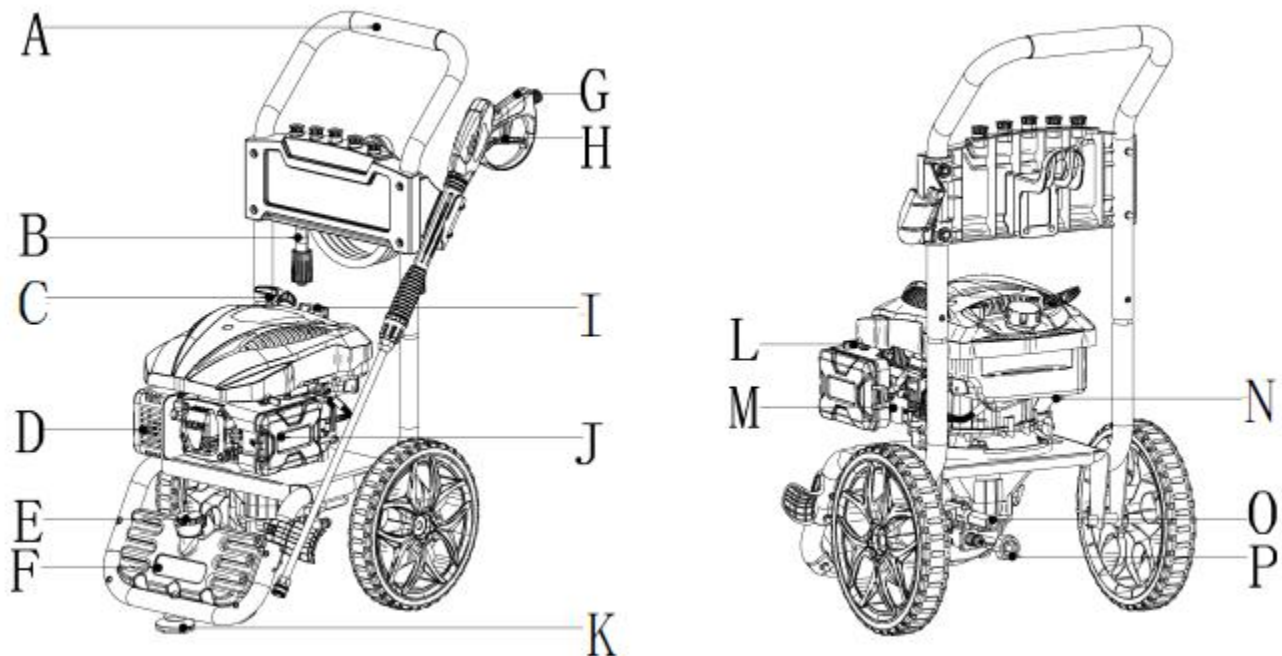



|   |                    |   |                 |   |                      |
|---|--------------------|---|-----------------|---|----------------------|
| A | Handle             | G | Spray Gun       | M | Engine ON/OFF Switch |
| B | High Pressure Hose | H | Locking Trigger | N | Dipstick             |
| C | Recoil Starter     | I | Fuel tank       | O | Water outlet         |
| D | Muffler            | J | Air cleaner     | P | Water inlet          |
| E | Detergent tank cap | K | Pad             |   |                      |
| F | Detergent tank     | L | Choke           |   |                      |

## TECHNICAL SPECIFICATIONS

|  |   |
|--|---|
| Type   | FNHPT240                                      |
| Rated pressure   | 20 MPa  |
| Allowable pressure   | 24 MPa  |
| Rated flow   | 9,8 l/min                                     |
| Max. flow  | 11 l/min                                      |
| Max. water intake temperature  | 60°C  |
| Max. inlet water pressure  | 0.55 MPa                                      |
| Net weight   | 30 kg   |
| Water hose diameter  | Min. $\varnothing$ 12.7mm                     |
| Kickback force on lance  | 28 N  |
| Sound power level and guaranteed sound   | 105 dB(A) K= 3 dB(A)                          |
| Sound pressure level   | 90 dB(A) K= 3 dB(A)                           |
| Vibration value  | 2,72 m/2 <sup>2</sup> K=0,85 m/s <sup>2</sup> |
| <ul style="list-style-type: none"><li>- Values determined according to noise test code given in Annex CC of EN 60335-2-79:2012, using the basic standard EN ISO 3744:2010.</li><li>- Values determined according to vibration test code given in Annex DD of EN 60335-2-79:2012, using the basic standard ISO 5349-1:2001.</li></ul> |   |

## 3. ASSEMBLY

 **WARNING!** Do not attempt to assemble or operate this pressure washer until you have read and understood this entire manual. If you have any problems assembling or operating this contact your dealer or a qualified service center.

 **WARNING!** Do not operate this pressure washer if any of the parts are damaged or missing until the part is replaced. Using this product with damaged or missing parts can cause damage to the machine or result in serious injury or death.

### Unpacking

Remove the product, parts, and all accessories. Make sure all items listed on the packing list are included and not damaged.

### Foot and wheel assembly

- Raise or tilt pressure washer so you can line up foot with the hole located at the center of the frame.
- Align the rubber foot with the hole in the frame where the foot is to be located. Attach foot by inserting the bolt from the bottom up and install the acorn nut. Wrench tightens until there is a slight crush on the frame tube (Do not over tighten).
- Pass the axle through the wheel, and then through the wheel bracket. Use the R pin to lock the wheel.

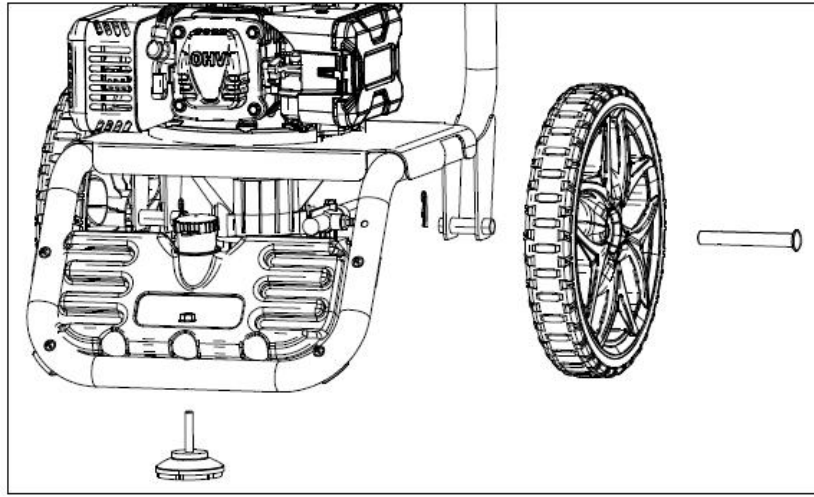

### **Handle assembly**

Install upper frame (handle) onto the lower frame by sliding the handle over the two upright tubes on the lower frame and pressing down firmly until the handle is seated and the two detent pins snap in place.

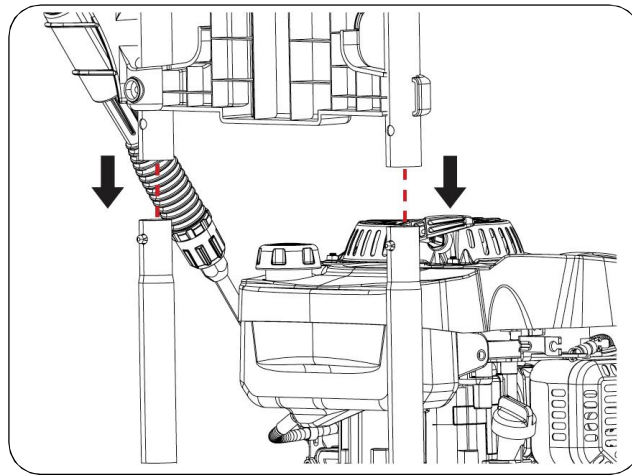

### **Attaching Upper and Lower Gun Hooks**

- Attach the upper gun hook, install two plastic rivets, until the plastic rivets are snug, you may need to tap with a mallet or small hammer to seat the lock pin.
- Attach the lower gun hook, install the M6 screw & lock nut, wrench tighten until the nut is snug, do not over tighten.

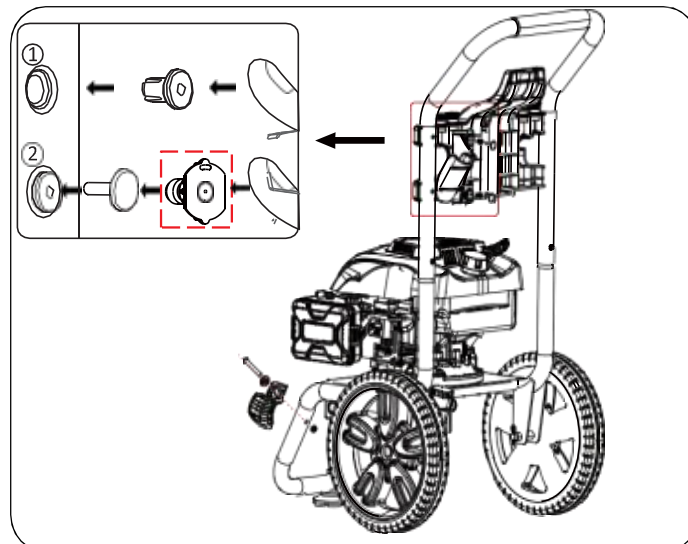

## Attaching the Spray Gun

- Screw the spray wand and the trigger handle together until they are secure.
- Insert the inlet coupler of the spray hose into the threaded fitting on the high pressure spray gun and thread the black nut on by turning clockwise until it is hand tight.

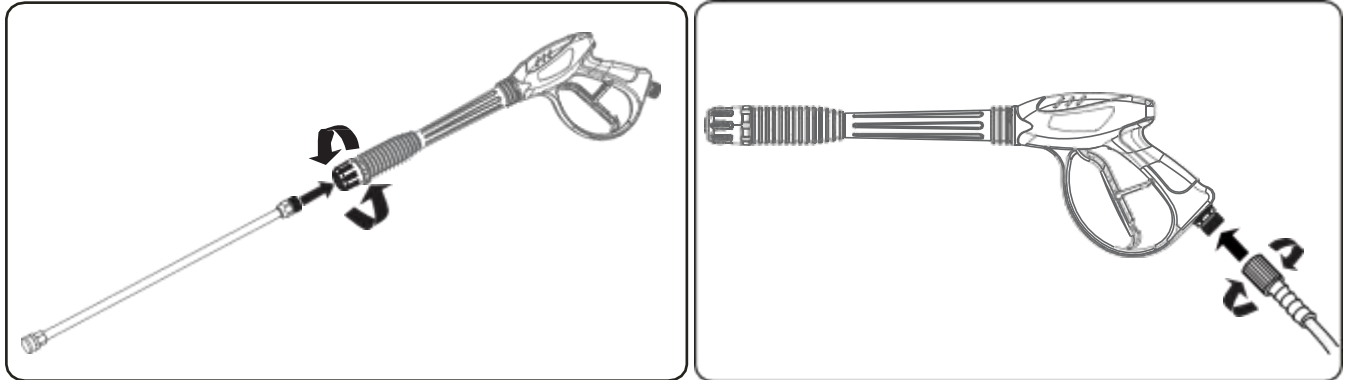

## Add engine oil

- Place pressure washer on a level surface.
- Open the oil tank.
- Carefully add between 400 ml (13.5 oz) of 4-Cycle engine oil (SAE10W30) in the tank.
- Close the oil tank.



## Adding Fuel

- Set pressure washer on a clean and level surface in an area that is well ventilated.
- Remove fuel cap.
- Insert a funnel into the fuel tank and carefully pour gasoline into the tank until fuel level reaches 1 1/2 inches below the top of the neck.

**⚠ CAUTION! Oil must be added to unit prior to first use.**

**⚠ CAUTION! To avoid spillage, do not overfill fuel tank as gasoline expands.**

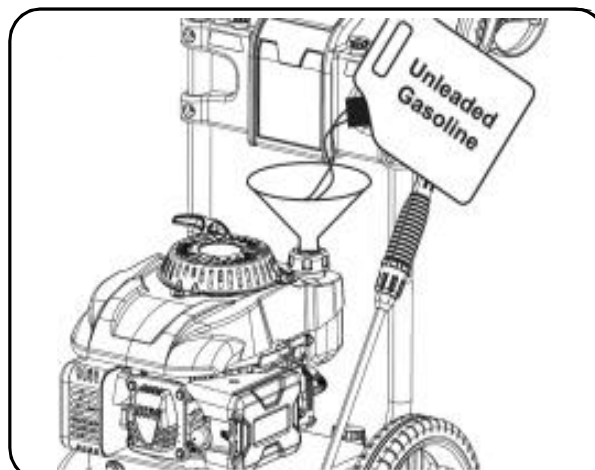

## Connecting Garden Hose to Pressure Washer

- Run water through the hose for a few seconds to flush and debris from the hose.
- Inspect inlet screen and remove any debris.
- Connect hose to water inlet and tighten by hand.
- Turn on water.
- Purge the system's pump of air by releasing the safety and squeezing the trigger of the spray gun.

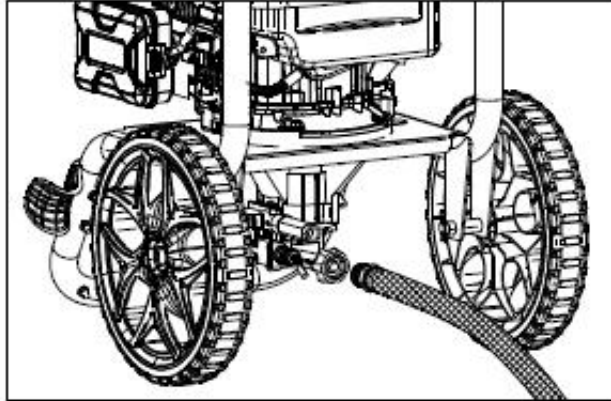

The minimum recommended length for the water supply pipe is 10 meters (but not more than 25 meters) with a diameter of 12.5 mm to avoid back pressure and any potential damage to your appliance. Make sure it can withstand water and a maximum pressure of 10bar (0.1Mpa). If you want to connect your device to other water sources, make sure the maximum water inlet pressure is 10bar (0.1Mpa).

## Connect High Pressure Hose to Pump

- Attach end of high pressure hose to the high pressure outlet on pump.

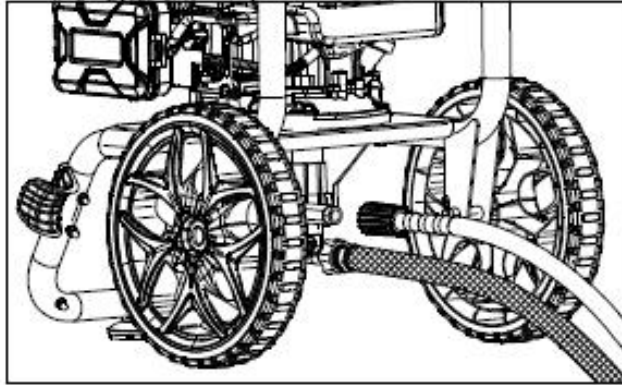

# 4. OPERATION

## Pre-Operation Check List

- Check oil level and add oil to the proper level if low.
- Check fuel level and add fuel if needed.
- Check connections of handle and all hoses to make sure they are secure.
- Check all hoses for kinks and damage.
- Check flow of water supply and make sure it is adequate.

**⚠ CAUTION!** Do not run pressure washer with a damaged hose. Do not run pressure washer without first connecting and turning on water supply or damage to the pressure washer could result. Failure to follow these instructions will void product warranty.

## Starting Pressure Washer

- Place pressure washer on a level surface.
- Turn on water.



- Slide the choke lever to the “Choke” position.
- Turn the engine OFF/ON switch to the “ON” position.
- Holding the machine with your hand, pull the recoil handle (starter cord) slowly until resistance is felt, then pull rapidly. Squeeze the Gun trigger and release the pressure after every failed attempt to start the pressure washer (This will reduce the back pressure).
- Let engine run for several seconds and then gradually slide the choke lever to the RUN position as the engine warms up until the choke is fully slid to the RUN position.

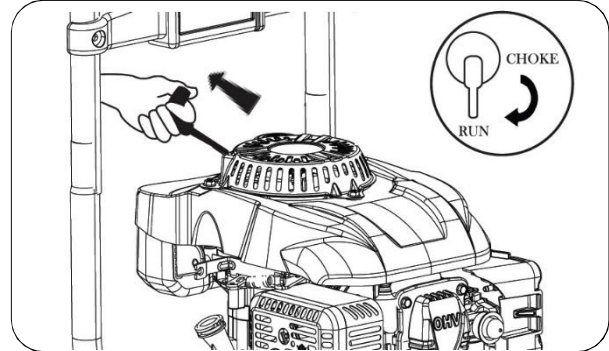
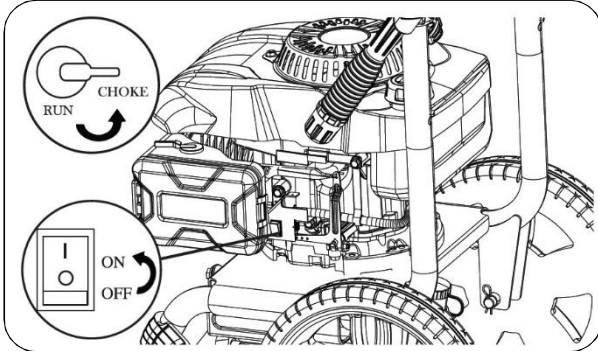

**WARNING! Do not quickly pull the starting cable, otherwise it may cause injury.**

- Before pulling the starter cable, always release the spray gun pressure, including every attempt to start the engine that fails.
- To avoid reversing, slowly pull the starter power cord until resistance is felt, then quickly pull it.

### Stopping Pressure Washer

- Turn the on/stop switch to the OFF position.
- Turn off water and squeeze the trigger handle to release all water pressure.

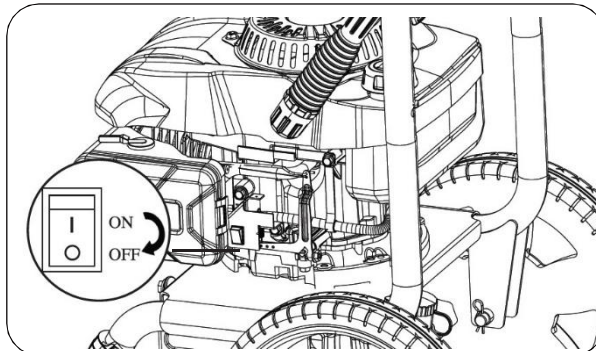

### Using the Spray Gun

- Flip the lock tab behind the trigger up or down until it clicks to apply or remove the safety. Pull back on the trigger to begin operating pressure washer.
- To stop water flow, release trigger.

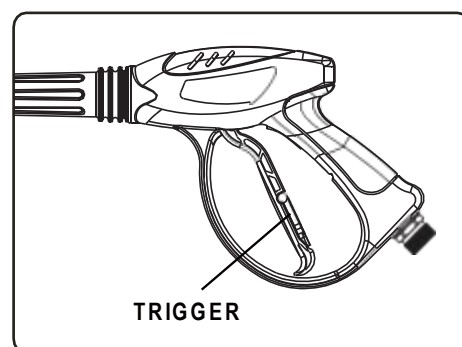
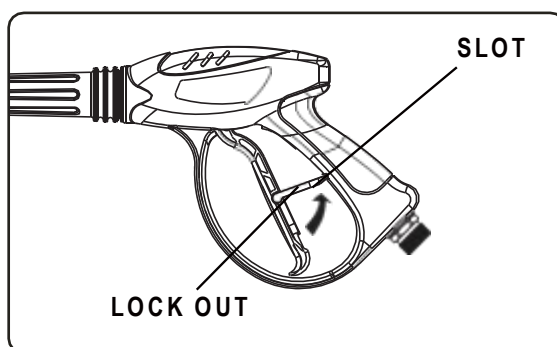

**WARNING! Kickback forces result from pressing the trigger! Therefore, always hold the spray gun with both hands! Pay attention to safe posture! Improper handling may result in injury!**

## Using Spray Nozzle

- To connect or disconnect spray tip, pull back on the quick-connect collar. Insert or remove spray tip then release collar.
- When spray tip is connected, pull on the spray tip to make sure it is secured.
- For general cleaning use the 40° spray tip. This option is for cement walkways.
- For stripping, spot cleaning, blasting, and hard to reach areas use the 25° spray tip. This option is for removing paint, rust, mildew, or grease stains. This option can be used for the removal of paint, rust, oil stains, tar, gum, and other stubborn substances. Use extreme caution when using this nozzle.
- For applying pressure washer safe detergent, use the black soap nozzle.
- The angle of the nozzles shown indicates the spray “fan shape” projected from the nozzle when the trigger of the spray gun is pulled and high pressure water is passing through the nozzle. The pressure and flow will not change significantly due to the various fan patterns (Nozzles).

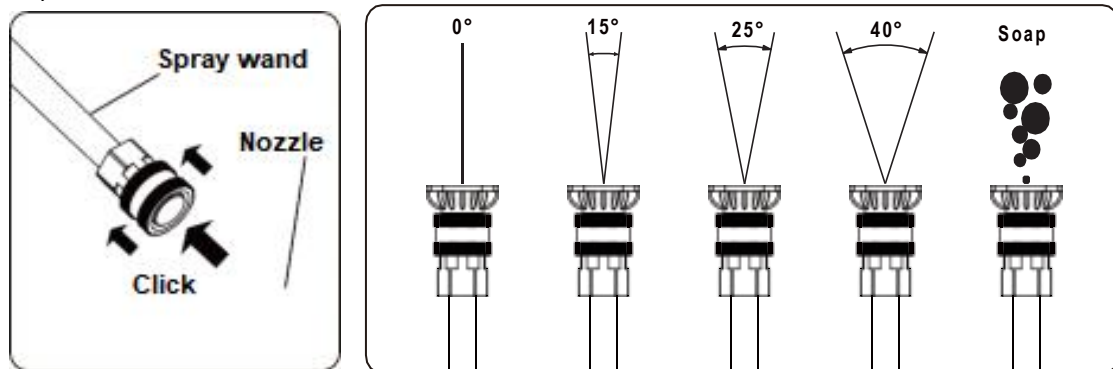

## Applying Detergent

- Rinse surface with cool water before applying cleaner.
- Prepare detergent as required by job. For best results follow detergent directions as supplied from manufacturer.
- Remove cap from detergent container and fill.
- Spray detergent on surface. For best results use long, even, and overlapping strokes. Allow detergent to set for about 3 minutes before rinsing, but do not allow detergent to dry on surface or it may cause streaking or cause damage to the surface.
- To clean the machine after use, rinse the nozzle with water for 1-2 minutes and then turn off the machine. Soak the nozzle in water to remove any traces of detergent.

**⚠ WARNING!** Only use mild, environmentally friendly detergents intended for use in pressure washers. Ask at your specialist dealer about these special products. Never use aggressive chemicals (e.g. bleach), abrasive detergents or similar to avoid damage to your health, the product and the environment.

**⚠ WARNING!** Avoid skin contact with detergents, especially the eyes! If detergent enters the eyes, rinse with clean water and seek medical attention immediately!

## Rinsing with the Pressure Washer

- Test a small area first to avoid surface damage.
- Rinse from top to bottom using long, overlapping strokes.

## Moving the Pressure Washer

- Turn the pressure washer off.
- Tilt unit towards you until it is balanced on its wheels.
- Roll machine to desired location.

## 5. MAINTENANCE AND STORAGE

Regular maintenance will extend the life of this pressure washer and improve its performance. The warranty does not cover items that result from operator negligence, misuse, or abuse. To receive full value from the warranty, operator must maintain the pressure washer as instructed in this manual, including proper storage.

**⚠️ WARNING!** Before inspecting or servicing this machine, make sure the engine is off and no parts are moving. Disconnect the spark plug wire and move it away from the spark plug.

### After Each Use

Follow the following procedure after each use:

- Shut off engine and turn off water supply. Release water pressure by pointing spray gun in a safe direction and squeezing the trigger.
- Disconnect high pressure hose, spray gun, and nozzle. Drain water from items and use a rag to wipe down the outside of the hose and spray gun.
- Empty the water from the pump by pulling the recoil starter 6 times.
- Store unit in a clean and dry area.

### Maintenance Schedule

|  |  |
|--|--|
| After First 5 Hours                    | Change Engine Oil  |
| After Each Use                         | Check and Clean Water Inlet screen                                     |
|  | Check High Pressure Hose   |
|  | Check and Clean Detergent Siphoning Tube                               |
|  | Check Spray Gun for Leaks  |
|  | Clean Debris   |
| Check Engine Oil Level before starting |  |
| Annually (20 hr. Use)                  | Change Engine Oil (Service more often under dirty or dusty conditions) |
| Annually (50 hr. Use)                  | Check and Clean Air Filter   |
| Annually (100 hr. Use)                 | Service or Replace Spark Plug  |

### Changing Engine Oil

Engine oil will drain better if the engine is still warm, but not hot.

- Shut off engine.
- Clean the area around the oil fill cap/dipstick to keep out debris then remove oil fill cap/dipstick.
- Place an oil pan on the ground to catch oil.
- Once oil is completely drained, return the pressure washer to a level position. Refill the engine with new oil as instructed earlier in this manual

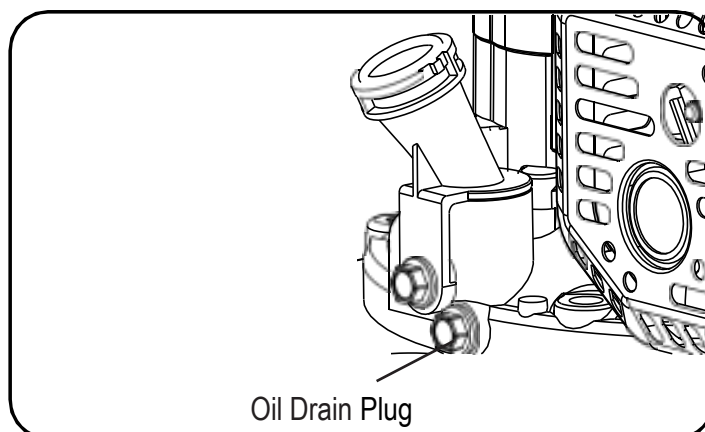



## Checking Detergent Siphoning Tube

- Check the detergent siphoning tube for clogs, leaks, or tears.
- Make sure the tube fits tightly to the pump fitting.
- Replace siphoning tubes if damaged.

 **WARNING! Never repair high pressure hose or use unit if hose is damaged. If hose is damaged replace with identical BUILDER part.**

## High Pressure Hose

- Inspect hose for cuts, bulges, or leaks which can develop from kinking or wear. If damage is found, immediately replace hose.
- Inspect couplings for damage. Immediately replace hose if damage is found.

## Spray Gun

- Make sure the spray gun is connected securely.
- Inspect the spray gun safety and make sure the spray gun trigger springs back upon release.

## Spray Nozzle

If a pulsing sensation is felt while squeezing the trigger, the spray nozzle may be dirty or clogged and should be cleaned immediately.

- To clean the nozzle, shut off the engine and turn off the water.
- Remove the nozzle from the spray wand making sure that the nozzle is pointing away from you and in a safe direction.
- Use the nozzle cleaner or a small paper clip to dislodge any foreign materials which are clogging or restricting the spray tip.
- Flush debris out of the nozzle by back flushing with a garden hose for 30-60 seconds.
- Reconnect the nozzle to the spray wand.
- Turn the water supply back on and start engine.

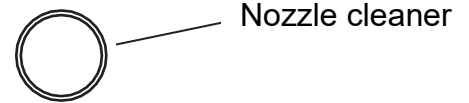

## Checking Spark Plug

- Disconnect the spark plug wire from the spark plug.
- Before removing the spark plug, clean the area around its base to prevent debris from entering the engine.
- Clean carbon deposits off the electrode with a wire brush.
- Check the electrode gap and slowly adjust to 0.80mm (0.031in.) if necessary.
- Reinstall spark plug and tighten to Torque 22.0 – 26.9 Nm (16-20 ft-lb).
- Reconnect spark plug wire.
- If spark plug is worn replace only with an equivalent replacement part. Spark plug should be replaced annually.

 **WARNING! Water pressure produced by this unit can cut through skin and tissue leading to serious injury and possible amputation.**

- Never attempt to repair high pressure hose, always replace.
- Never attempt to repair leaks with sealant, always replace O-ring or seal.

## Repairing Leaking Connections

- Purchase O-Ring / Maintenance kits through the nearest authorized service center and follow instructions provided with kit.

## Air Filter

A dirty air filter will reduce the life span of the engine, make starting the engine difficult, and reduce the unit's performance.

- To clean, remove the air filter cover.

- Carefully pull the air filter out by lifting up along the edges.
- Remove dirt from filter by tapping on it or having it blown out.
- Reinstall air filter so that it seals and replace air filter cover.

 **WARNING! Storage cover could be flammable. Let engine cool before covering pressure washer.**

## Storing Pressure Washer

If storing pressure washer for 30 days or more follow the procedures below:

- Add fuel stabilizer to gasoline to keep gasoline from going stale and to prevent gum deposits from forming on the carburetor. Run engine for a couple of minutes to circulate the fuel stabilizer.
- Add Pump Saver to protect pump from freezing or damage caused by mineral deposits.
- Empty fluid from all hoses and pump.
- Disconnect the spark plug wire and clean the spark plug. Leave spark plug wire disconnected.
- Clean the air filler.
- Cover unit with a suitable protective cover to keep unit dry.
- Store unit in a frost-free area.

## 6. TROUBLESHOOTING

| PROBLEM  | CAUSE   | SOLUTION  |
|--|---|---|
| Engine does not start                                      | Out of fuel   | Fill fuel tank  |
|  | Engine oil low                                      | Add engine oil  |
|  | Spark plug wire disconnected from spark plug        | Connect spark plug wire   |
|  | Bad spark plug                                      | Replace spark plug  |
|  | Spark plug wire has shorted                         | Contact service center  |
|  | Ignition inoperative                                | Contact service center  |
| Engine hard to start                                       | Stale fuel or water in fuel                         | Drain fuel and refill with fresh gasoline   |
|  | Spark plug producing weak spark                     | Contact service center  |
|  | Excessively rich fuel mixture                       | Contact service center  |
| Engine lacks power and vibrates excessively                | Dirty air filter                                    | Clean air filter  |
| Engine quits during operation                              | Out of fuel   | Fill fuel tank  |
| Engine loses power when load is added                      | Engine speed is too slow                            | Move throttle to fast. If this does not correct problem, contact service center   |
| Water pressure is weak                                     | Water supply is restricted.                         | Inspect garden hose for kinks or leaks. Make sure you are using a large enough garden hose (min. $\frac{3}{4}$ inch diameter) |
|  | Water not turned on to full power                   | Open water source all the way.  |
|  | Not using high pressure nozzle                      | Change nozzle   |
| Detergent and spray do not mix                             | Detergent hose is not submerged or has disconnected | Make sure hose is connected and submerged in the detergent  |
|  | Black soap nozzle needed                            | Install soap nozzle   |
| Pump fails to produce pressure or pressure is inconsistent | Water supply is restricted                          | Inspect garden hose for kinks or leaks. Make sure you are using a large enough garden hose (Min. $\frac{3}{4}$                |

|  |                                |   |
|--|--------------------------------|---|
|  |                                | inch diameter)                                  |
|  | Water not turned on full power | Open water source all the way.                  |
|  | Nozzle is clogged              | Clean nozzle                                    |
|  | Spray gun leaks                | Check spray gun connection or replace spray gun |
|  | Air in line                    | Squeeze trigger handle to remove air            |
|  | Inlet hose screen is clogged   | Clean inlet                                     |
|  | Water supply is over 100°F     | Use cool water supply                           |
|  | Pump is faulty                 | Contact service center                          |

## 7. WIRING DIAGRAM

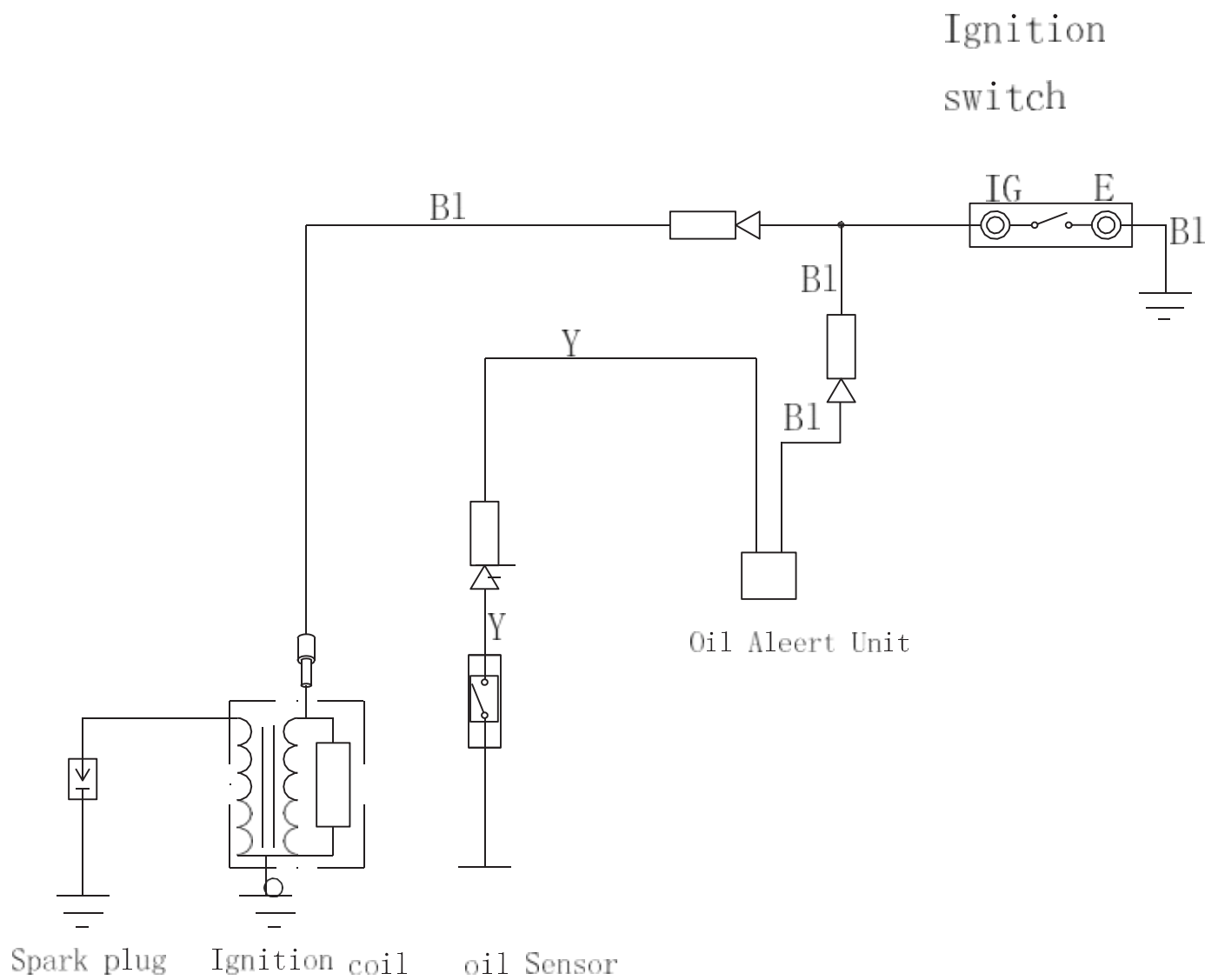

|     |   |    |
|-----|---|----|
|     | E | IG |
| OFF | — | ○  |
| ON  |   |    |

|    |        |
|----|--------|
| B1 | Black  |
| Y  | Yellow |

## 8. DECLARATION OF CONFORMITY



BUILDER SAS

ZI, 32 rue Aristide Bergès – 31270 Cugnaux - France

Declares that the machinery designated below:

PETROL HIGH PRESSURE WASHER

Ref.: FNHPT240

Serial number: 20250203566-20250203733

Complies with the provisions of the Directive “machinery” 2006/42/CE and national laws transposing it:

Also complies with the following European directives:

EMC Directive 2014/30/EU

ROHS Directive (EU)2015/863 amending 2011/65/EU

Emission directive (EU) 2016/1628 & 2017/656/EU

Directive on environmental noise emissions from equipment intended for use outside buildings  
2000/14/EC Annex V and Directive 2005/88/EC

Guaranteed Sound Power Level: 105 dB(A)

Also complies with European standards, with national standards and the following technical provisions:

EN 60335-1:2012+A11+A13+A14+A2+A15

EN60335-2-79:2012

EN 55012:2007+A1 :2009

EN 61000-6-1:2007

Cugnaux, on 01/01/2025

Philippe MARIE / PDG

## 9. WARRANTY



### WARRANTY

The manufacturer guarantees the product against defects in material and workmanship for a period of 5 years from the date of the original purchase. The warranty only applies if the product is for household use. The warranty does not cover breakdowns due to normal wear and tear.

The manufacturer agrees to replace parts identified as defective by the designated distributor. The manufacturer does not accept responsibility for the replacement of the machine, in whole or in part, and/or ensuing damage.

**The warranty does not cover breakdowns due to:**

- insufficient maintenance.
- abnormal assembly, adjustment or operations of the product.
- parts subject to normal wear and tear.

**The warranty does not extend to:**

- shipping and packaging costs.
- using the tool for a purpose other than that for which it was designed.
- the use and maintenance of the machine done in a manner not described in the user manual.

Due to our policy of continuous product improvement, we reserve the right to alter or change specifications without notice. Consequently, the product may be different from the information contained therein, but a modification will be undertaken without notice if it is recognized as an improvement of the preceding characteristic.

**READ THE MANUAL CAREFULLY BEFORE USING THE MACHINE.**

When ordering spare parts, please indicate the part number or code, you can find this in the spare parts list in this manual. Keep the purchase receipt; without it, the warranty is invalid. To help you with your product, we invite you to contact us by phone or via our website:

- **+33 (0)9.70.75.30.30**
- **<https://services.swap-europe.com/contact>**

You must create a "ticket" via the web platform.

- Register or create your account.
- Indicate the reference of the tool.
- Choose the subject of your request.
- Describe your problem.
- Attach these files: invoice or sales receipt, photo of the identification plate (serial number), photo of the part you need (for example: pins on the transformer plug which are broken).



# 10. PRODUCT FAILURE

## WHAT TO DO IF MY MACHINE BREAKS DOWN?

### **If you bought your product in a store:**

a) Empty the fuel tank if your product has one.

b) Make sure that your machine is complete with all accessories supplied, and clean! If this is not the case, the repairer will refuse the machine.

Go to the store with the complete machine and with the receipt or invoice.

### **If you bought your product on a website:**

a) Empty the fuel tank if your product has one.

b) Make sure that your machine is complete with all accessories supplied, and clean! If this is not the case, the repairer will refuse the machine.

c) Create a SWAP-Europe service ticket on the site: <https://services.swap-europe.com> When making the request on SWAP-Europe, you must attach the invoice and the photo of the nameplate (serial number).

d) Contact the repair station to make sure it is available before dropping of the machine.

Go to the repair station with the complete machine packed, accompanied by the purchase invoice and the station support sheet downloadable after the service request is completed on the SWAP-Europe site

For machines with engine failure from manufacturers BRIGGS & STRATTON, HONDA and RATO, please refer to the following instructions.

Repairs will be done by approved engine manufacturers of these manufacturers, see their site:

- <http://www.briggsandstratton.com/eu/fr>
- <http://www.honda-engines-eu.com/fr/service-network-page;jsessionid=5EE8456CF39CD572AA2AEEDFD290CDAE>
- <https://www.rato-europe.com/it/service-network>

**Please keep your original packaging to allow for after-sales service returns or pack your machine with a similar cardboard box of the same dimensions.**

**For any question concerning our after-sales service you can make a request on our website <https://services.swap-europe.com>**

**Our hotline remains available at +33 (9) 70 75 30 30.**



# 11. WARRANTY EXCLUSIONS

## THE WARRANTY DOES NOT COVER:

- Start-up and setting up of the product.
- Damage resulting from normal wear and tear of the product.
- Damage resulting from improper use of the product.
- Damage resulting from assembly or start-up not in accordance with the user manual.
- Breakdowns related to carburetion beyond 90 days and fouling of carburetors.
- Periodic and standard maintenance events.
- Actions of modification and dismantling that directly void the warranty.
- Products whose original authentication marking (brand, serial number) has been degraded, altered or withdrawn.
- Replacement of consumables.
- The use of non-original parts.
- Breakage of parts following impacts or projections.
- Accessories breakdowns.
- Defects and their consequences linked to any external cause.
- Loss of components and loss due to insufficient screwing.
- Cutting components and any damage related to the loosening of parts.
- Overload or overheating.
- Poor power supply quality: faulty voltage, voltage error, etc.
- Damages resulting from the deprivation of enjoyment of the product during the time necessary for repairs and more generally the costs related to the immobilization of the product.
- The costs of a second opinion established by a third party following an estimate by a SWAP-Europe repair station
- The use of a product which would show a defect or a breakage which was not the subject of an immediate report and/or repair with the services of SWAP-Europe.
- Deterioration linked to transport and storage\*.
- Launchers beyond 90 days.
- Oil, petrol, grease.
- Damages related to the use of non-compliant fuels or lubricants.

\* In accordance with transport legislation, damage related to transport must be declared to carriers within 48 hours maximum after observation by registered letter with acknowledgement of receipt.

This document is a supplement to your notice, a non-exhaustive list.

**Attention:** all orders must be checked in the presence of the delivery person. In case of refusal by the delivery person, it you must simply refuse the delivery and notify your refusal.

**Reminder:** the reserves do not exclude the notification by registered letter with acknowledgement within 72 hours.

### Information:

Thermal devices must be wintered each season (service available on the SWAP-Europe site). Batteries must be charged before being stored.

# FEIDER



CE

BUILDER SAS

32 rue Aristide Bergès - Z.I. du Casque - 31270 Cugnaux - France

Made in PRC